

RAK7246G WisGate Developer D0 Gateway Datasheet

Overview

Description

The RAK7246G is a LoRaWAN Developer gateway with GPS function. It is a device composed of a the RAK2246 Pi HAT LPWAN Concentrator module and Raspberry Pi Zero W.

The RAK2246 Pi HAT is based on a Semtech SX1308 chip, which allows for simultaneous reception over 8 LoRa channels, which cover the entirety of the international high frequency LoRaWAN space.

The RAK7246G is an ideal choice for prototype design, concept verification and demonstrations, development evaluation and other scenarios. It is developer friendly due to its minimalistic design that reduces cost and allows for easily accessing the internals. It is easy to set-up, which makes it a good choice for both experienced and novice LoRa specialists.

Features

- Using **SX1308** baseband processor couple with dual **SX1257**, full 8 uplink channels and 1 downlink channel LoRaWAN Gateway
- Built-in Ublox **MAX-7Q GPS** module
- The Pre-installed radiator guarantees stable thermal performance
- Tx max **20dbm**, Rx min **-139dbm @ SF12** at 125kHz
- Covers the entirety of the **LoRa high frequency band space**: RU864, IN865, EU868, US915, AU915, KR920, AS923;
- Power supply rating **5V / 2.5A (not included)**.

Specifications

Overview

The overview covers the RAK7246G board overview and the block diagram that shows how the componets operatate.

Board Overview

Module Overview

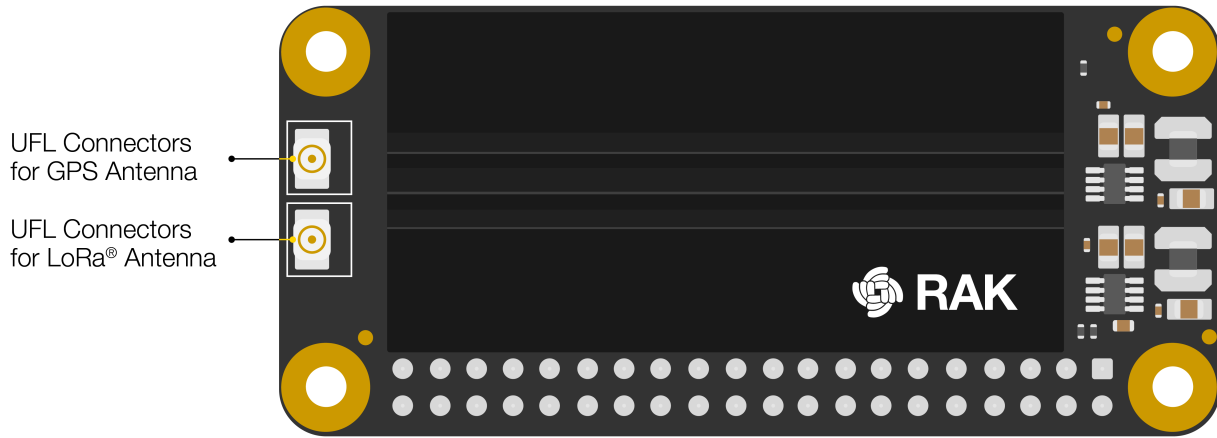

Figure 1: uFL Connectors for LoRa and GPS

The Interfaces of the RAK7246G are as shown in Figure 2. The TF card slot is used for the SD card that houses the Firmware (based on Raspbian OS). You have two SMA connectors for the LoRa and GPS antennas. There are 3 ports on the side, which are part of the Raspberry Pi Zero W board, which from left to right are: mini HDMI, USB MicroB, and another USB MicroB/Power (please only use this to power the device with the included adapter or an equivalent one).

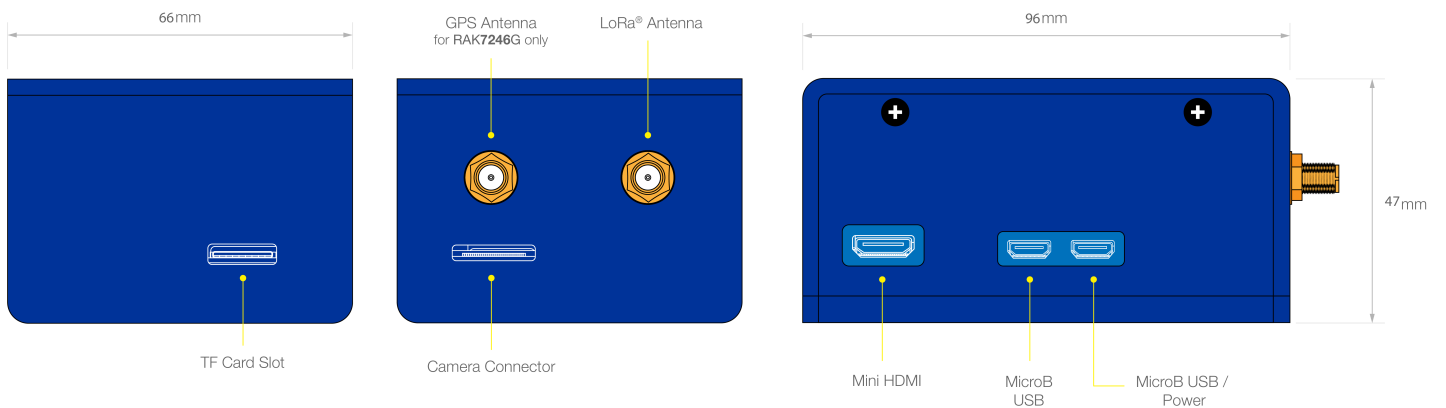

Figure 2: Hardware Interfaces

Board Dimension

Both the RAK2246 and Raspberry Pi have the same board dimensions: **30 x 65 mm**. As for the size of the Gateway with the casing refer to the Figure below.

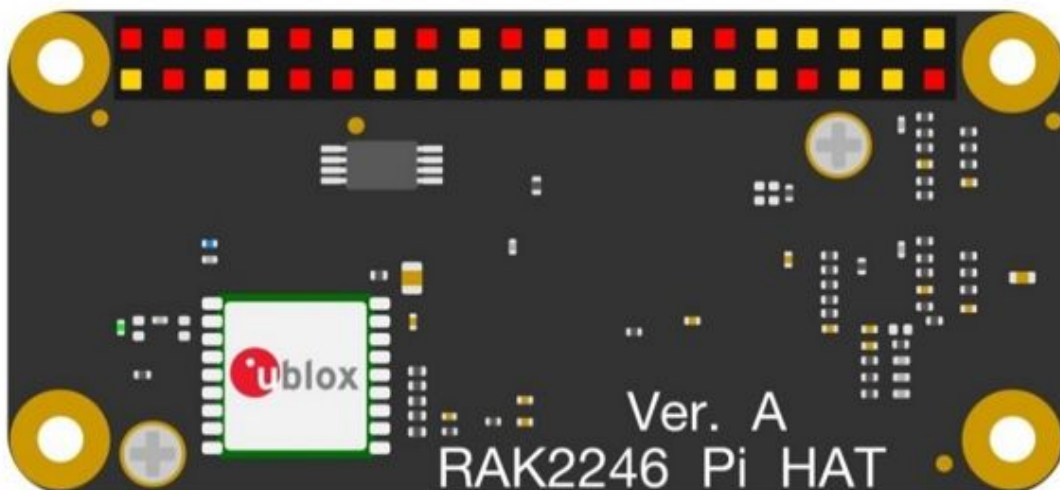

Figure 3: Casing Dimension

Block Diagram

RAK2246 Concentrator

The concentrator is available with an SPI interface:



BOTTOM VIEW

Figure 4: RAK2246 Bottom View

SX1308

The RAK2246 includes Semtech's SX1308, which is a digital baseband chip including a massive digital signal processing engine specifically designed to offer breakthrough gateway capabilities in the worldwide ISM band.

The SX1308 is a smart baseband processor for long range ISM communication. In the receiver part, it receives I and Q digitized bit stream for one or two receivers (SX1257), demodulates these signals using several demodulators, adapting the demodulators settings to the received signal and stores the received demodulated

packets in a FIFO to be retrieved from a host system (PC, MCU). In the transmitter part, the packets are modulated using a programmable (G)FSK/LoRa modulator and sent to one transmitter (SX1257). Received packets can be time-stamped using a GPS PPS input.

The SX1308 has an internal control block that receives microcode from the host system (PC, MCU). The microcode is provided by Semtech as a binary file to load into the SX1308 at power-on (see *Semtech application support for more information*).

The control of the SX1308 by the host system (PC, MCU) is made using a Hardware Abstraction Layer (HAL). The Hardware Abstraction Layer source code is provided by Semtech and can be adapted by the host system developers.

It is highly recommended to utilize the latest HAL as provided by Semtech on <https://github.com/Lora-net>

Block Diagram

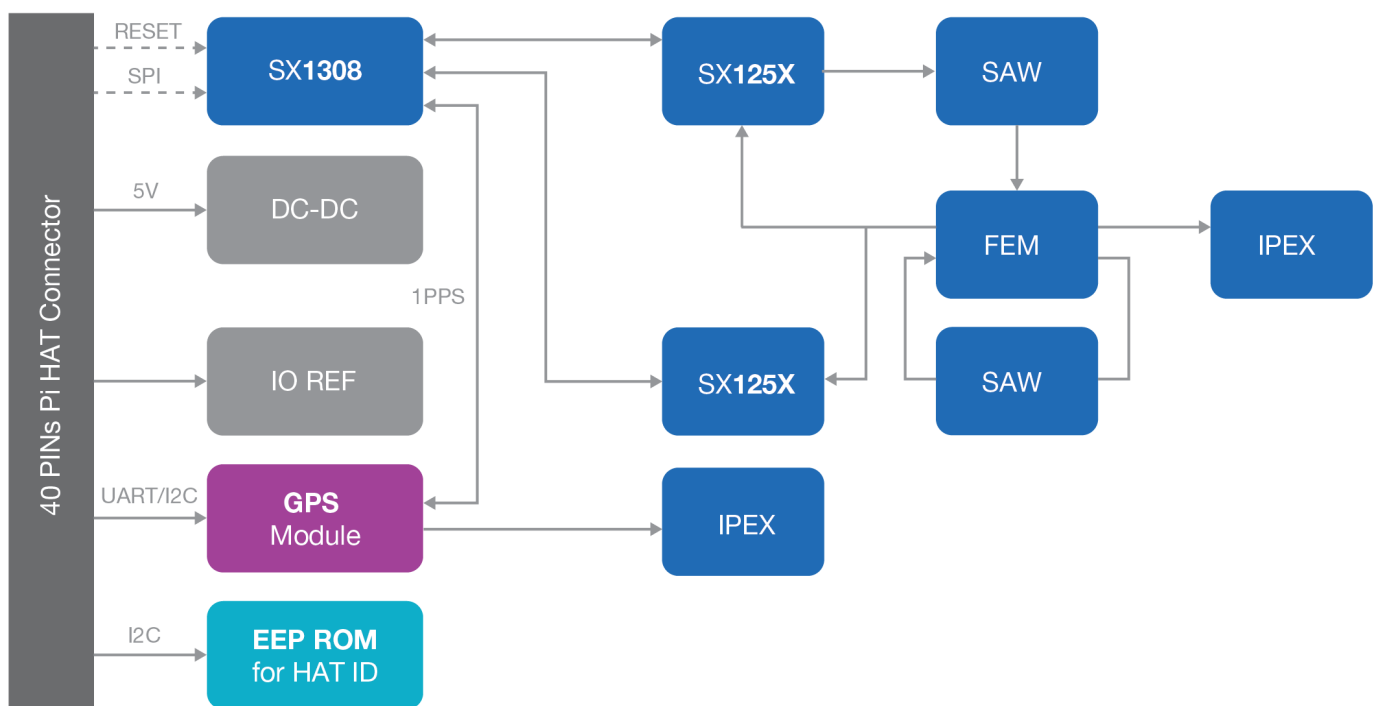

Figure 5: Block Diagram

The SX1308 digital baseband chip contains 10 programmable reception paths. Those paths have differentiated levels of programmability and allow for different use cases. It is important to understand the differences between those demodulation paths to make the best possible use of the system.

IF8 LoRa channel

This channel is connected to one SX1257 using any arbitrary intermediate frequency within the allowed range. This channel is LoRa only. The demodulation bandwidth can be configured to be 125, 250 or 500 kHz. The data rate can be configured to any of the LoRa available data rates (SF7 to SF12), but as opposed to the IF0 to IF7 channels, only the configured data rate will be demodulated. This channel is intended to serve as a high speed backhaul link to other gateways or infrastructure equipment. This demodulation path is compatible with the signal transmitted by the SX1272 and SX1276 chip family.

IF9 (G)FSK channel

The IF9 channel is connected to a (G)FSK demodulator. The channel bandwidth and bit rate can be adjusted. This demodulator offers a very high level of configurability, going well beyond the scope of this document. The demodulator characteristics are essentially the same as the (G)FSK demodulator implemented in the SX1232 and SX1272 Semtech chips. This demodulation path can demodulate any legacy FSK or GFSK formatted signal.

IF0 to IF7 LoRa channels

These channels are connected to one SX1257. The channel bandwidth is 125 kHz and cannot be modified or configured. Each channel's IF frequency can be individually configured. On each of these channels any data rate can be received without prior configuration.

Several packets using different data rates (different SF) may be demodulated simultaneously even on the same channel. Those channels are intended to be used for a massive asynchronous star network of 1000's of sensor nodes. Each sensor may use a random channel (amongst IF0 to IF7) and a different data rate for any transmission.

Sensors located near the Gateway will typically use the highest possible data rate in the fixed 125 kHz channel bandwidth (e.g. 6 kbit/s) while sensors located far away will use a lower data rate down to 300 bit/s (the minimum LoRa data rate in a 125 kHz channel).

The SX1308 digital baseband chip scans the 8 channels (IF0 to IF7) for preambles of all data rates at all times.

The chip is able to demodulate simultaneously up to 8 packets. Any combination of spreading factor and intermediate frequency for up to 8 packets is possible (e.g. one SF7 packet on IF0, one SF12 packet on IF7 and one SF9 packet on IF1 simultaneously).

The SX1308 can detect simultaneously preambles corresponding to all data rates on all IF0 to IF7 channels. However, it cannot demodulate more than 8 packets simultaneously. This is because the SX1308 architecture separates the preamble detection and signal acquisition task from the demodulation process. The number of simultaneously demodulated packets (in this case 8) is an arbitrary system parameter and may be set to other values for a customer specific circuit.

The unique multi data-rate multi-channel demodulation capacity SF7 to SF12 and of channels IF0 to IF7 allows innovative network architectures to be implemented.

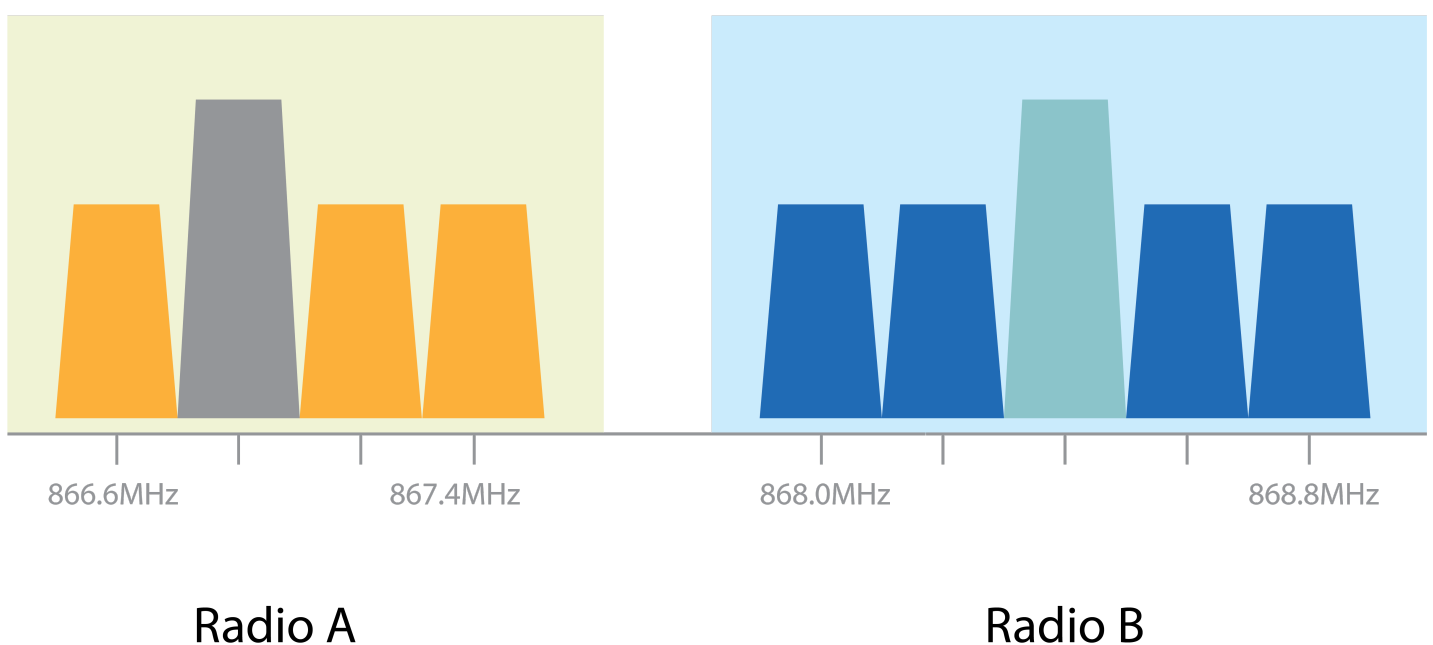
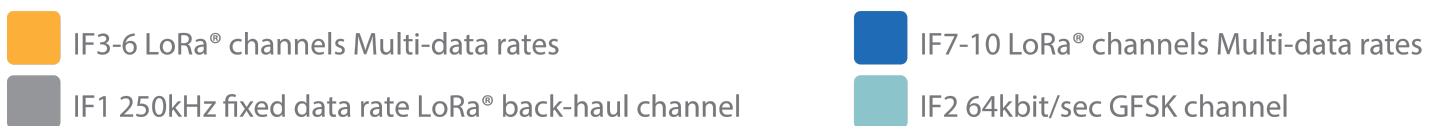

Figure 6: LoRa Channel

Hardware

The hardware specification is categorized into four parts. It includes the interfacing, pinouts and its corresponding functionalities and diagram. It also presents the features of RAK7246G and its parameters.

Interfaces

External Module Interfaces

SPI

The PINs on the connector provide an SPI connection, which allows direct access to the SX1308 SPI interface. This gives the target system the possibility to use existing SPI interfaces to communicate.

NOTE

After powering up RAK2246, it is required to reset SX1308 via PIN 11.

UART and I2C

The PINs on the bottom side provide an UART connection and I2C connection, which allows direct access to the GPS module. The 1PPS has been connected to the SX1308 internally.

Digital IOs

There are two digital IO PINs, which give the user an interface to reset the GPS module or set it into standby mode.

Pin Definition

RAK2246 Pi Hat PINOUT

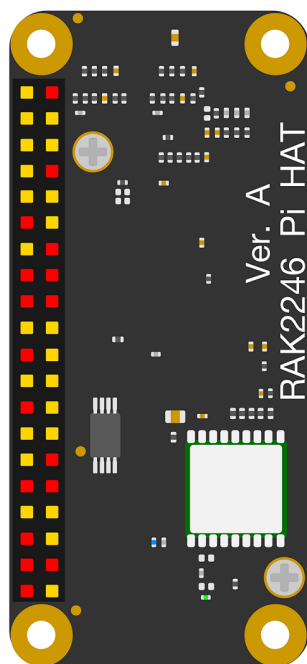

BOTTOM VIEW

- Pins with connection
- Pins with no connection

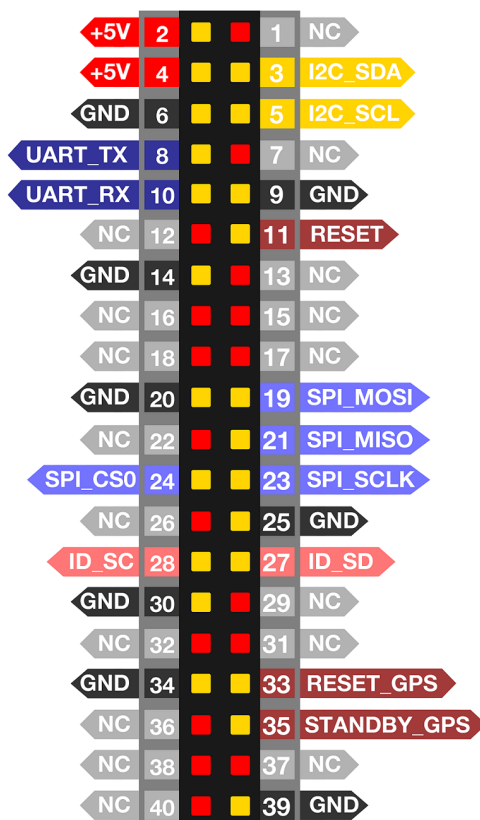

Figure 7: RAK7246G Pinout Diagram

Pin	Name	Description
1	NC	Not Connected
2	+5V	+5V Supply Voltage
3	SDA	I2C_SDA (Connected to GPS Module I2C_SDA)
4	+5V	+5V Supply Voltage
5	SCL	I2C_SCL (Connected to GPS Module I2C_SCL)
6	GND	Ground
7	NC	Not Connected
8	UART_TX	It should be connected to the RPi's UART_TXD. It has been connected to the GPS Module's UART_RXD internally.
9	GND	Ground
10	UART_RX	It should be connected to the RPi's UART_RXD. It has been connected to the GPS Module's UART_TXD internally.
11	RESET	SX1308 RESET (GPIO17 of RPi)
12	NC	Not Connected
13	NC	Not Connected
14	GND	Ground
15	NC	Not Connected
16	NC	Not Connected
17	NC	Not Connected
18	NC	Not Connected
19	SPI_MOSI	It should be connected to the RPi's SPI_MOSI. It has been connected to the SX1308's SPI_MOSI internally.
20	GND	Ground
21	SPI_MISO	It should be connected to the RPi's SPI_MISO. It has been connected to the SX1308's SPI_MISO internally
22	NC	Not Connected
23	SPI_SCLK	It should be connected to the RPi's SPI_SCLK. It has been connected to the SX1308's SPI_CLK internally.

Pin	Name	Description
24	SPI_CE0	It should be connected to the RPi's SPI_CE0. It has been connected to the SX1308's SPI_CS internally.
25	GND	Ground
26	NC	Not Connected
27	ID_SD	I2C_SDA for HAT ID EEPROM
28	ID_SC	I2C_SCL for HAT ID EEPROM
29	NC	Not Connected
30	NC	Not Connected
31	NC	Not Connected
32	NC	Not Connected
33	RESET_GPS	GPS Module reset PIN (GPIO13 of RPi)
34	GND	Ground
35	STANDBY_GPS	GPS Module standby PIN (GPIO19 of RPi)
36	NC	Not Connected
37	NC	Not Connected
38	NC	Not Connected
39	GND	Ground
40	NC	Not Connected

Main Specifications

The following table shows the available features of the RAK7246G WisGate Developer D0 Gateway and its corresponding specifications:

Feature	Specifications
Computing	<ul style="list-style-type: none"> • Raspberry Pi Zero Wireless (BCM2835, ARMv7) • Memory: 512MB • Storage: SD card slot
WiFi Feature	<ul style="list-style-type: none"> • Frequency: 2.400-2.4835GHz (802.11b/g/n) • RX Sensitivity: -99dBm • TX Power: 21dBm
LoRa Feature	<ul style="list-style-type: none"> • RAK2246 LoRaWAN Concentrator • Semtech SX1308 with dual SX1257 • Up to 8 Uplink and 1 Downlink channel • RX Sensitivity: -139 dBm • TX Power: 20 dBm (Max) • Frequency bands supported: RU864 / IN865 / EU868 / US915 / AU915 / KR920 / AS923
Power Supply	<ul style="list-style-type: none"> • DC 5V / 2.5A
Power Consumption	<ul style="list-style-type: none"> • 5W (average)
Antennas	<ul style="list-style-type: none"> • LoRa: RP-SMA Female Connector • GPS: SMA Female • WiFi: Internal Antenna
LEDs	<ul style="list-style-type: none"> • POWER/STATUS LED
Ingress Protection	<ul style="list-style-type: none"> • IP30
Enclosure Material	<ul style="list-style-type: none"> • Plastic
Weight	<ul style="list-style-type: none"> • 300g
Dimension	<ul style="list-style-type: none"> • 96mm x 66mm x 47mm
Operating Temperature	<ul style="list-style-type: none"> • -10 to 65°C

RF Characteristics

LoRa

Feature	Specifications
Operating Frequency	<ul style="list-style-type: none"> • EU433, CN470, EU868, US915 • AS920, AS923, AU915, KR920, IN865
Transmit Power	27dBm (Max)
Receiver Sensitivity	-142dBm (Min)

Transmitter RF

The RAK2246 has an excellent transmitter performance. It is highly recommended, to use an optimized configuration for the power level configuration, which is part of the HAL. This results in a mean RF output power level and current consumption:

MIX Control	DIG Gain	Nominal RF Power Level [dBm]
8	0	10
9	0	12
10	0	14
11	0	16
12	0	18
13	0	19
14	0	20
15	0	21

T=25°C, VDD=5V (Typ.) if nothing else stated

Parameter	Condition	Min	Typ.	Max	Unit
Frequency Range		863		870	MHz
Modulation Techniques	FSK/LoRa				
TX Frequency Variation vs. Temperature	Power Level Setting: 20dBm	-3		+3	KHz
TX Power Variation vs. Temperature		-5		+5	dB
TX Power Variation		-1.5		+1.5	dB

 **NOTE**

Also supports 915 Frequency Range.

Receiver RF

It is highly recommended, to use optimized RSSI calibration values, which is part of the HAL v3.1. For both, Radio 1 and Radio 2, the RSSI-Offset should be set to -169.0. (It is highly recommended, to use optimized RSSI calibration values, which is part of the HAL v3.1. For both, Radio 1 and Radio 2, the RSSI-Offset should be set to -169.0.)

The following table gives typically sensitivity level of the RAK2246:

Signal Bandwidth [KHz]	Spreading Factor	Sensitivity [dBm]
125	12	-141
125	7	-128
250	12	-137
250	7	-124
500	12	-135
500	7	-121

RF Key Components

This section introduces the key components in the RAK2246 in order to help developers to utilize the system at its fullest in their designs.

1. DC-DC regulator

The system power supply is provided by an external 5V DC power supply. All the key components and related clock crystals are powered by two DC-DC regulators (MP1496) which output 1.8V and 3.3V in order to meet the normal working conditions. The MP1496 is a high-frequency, synchronous, rectified, step-down, switch-mode converter with built-in power MOSFETs. It offers a very compact solution to achieve a 2A continuous output current with excellent load and line regulation over a wide input supply range.

2. FEM

The FEM chosen is a SKYWORCS SKY66422, which integrates a PA, LNA and a Switch. It can achieve a 20 dBm max output power in order to deliver sufficient RX performance. The frequency range it can cover from is 860MHz~930MHz.

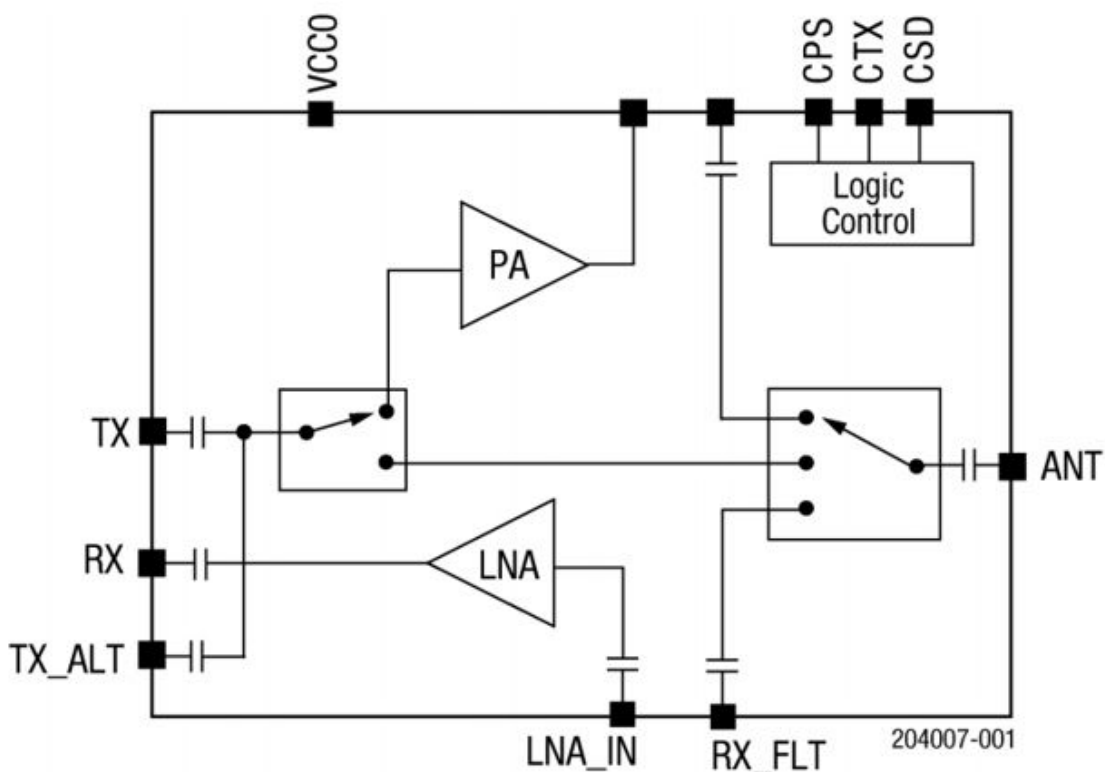

SKY66422-11 Block Diagram

Figure 8: System Architecture

Wi-Fi

Features	Specifications
Wireless Standard	IEEE 802.11b/g/n
Operating Frequency	ISM band: 2.412~2.472(GHz)
Operation Channels	2.4GHz: 1-13
Transmit Power (The max. power may be different depending on local regulations) - per chain	- 802.11b - @1Mbps : 19dBm, @11Mbps : 19dBm - 802.11g - @6Mbps : 18dBm, @54Mbps : 16dBm - 802.11n (2.4G) - @MCS0 (HT20) : 18dBm, @MCS7 (HT20) : 16dBm,@MCS0 (HT40) : 17dBm, @MCS7 (HT40) :15dBm
Receiver Sensitivity (Typical)	- 802.11b - @1Mbps : -95dBm, @11Mbps : -88dBm - 802.11g - @6Mbps : -90dBm, @54Mbps : -75dBm - 802.11n (2.4G) - @MCS0 (HT20) : -89dBm, @MCS7(HT20) : -72dBm,@MCS0(HT40) : -86dBm, @MCS7(HT40) : -68dBm

Software

Download the latest firmware of RAK7246G in the table provided below. The supported software features are also included with the standard parameters.

Firmware

Model	Raspberry Pi Board	Firmware Version	Source
RAK7246	Raspberry Pi Zero W	4.2.0R	Download 

Software Specifications

LoRa	Network	Management
Class A, C	Wi-Fi AP/Client mode	SSH2
LoRa package forwarder	DHCP Client	
Country code setup		
TX power setup		
Location setup		
Supports server address & port setup		

LoRaWAN Systems, Network Approach

The use of LoRaWAN technology can be distinguished in “Public” and “Private” networks. In both cases the usage of a concentrator module is a must if a multichannel performance is sought after. Public networks are operator (e.g. telecom) managed networks whereas private networks are individually managed networks.

LoRaWAN networks are typically star or multiple star networks where a Gateway relays the packets between the end-nodes and a central network server. For private network approaches the server can also be implemented on the Gateway host.

Due to the long range LoRa provides the connection between the end-nodes and the Gateway (RAK2246) is always a direct link. Repeaters are not common in a LoRaWAN network.

Depending on the used spreading factor and signal bandwidth different data rates (0.3 kbps to ~22 kbps) and sensitivities down to -142.5 dBm are possible. Spreading factor and signal bandwidth are a trade-off between data rate and communication range.

Overview

The RAK2246 is able to receive on different frequency channels at the same time and is able to demodulate the LoRa signal without knowledge of the used spreading factor of the sending node. Thus, any Gateway using it as its concentrator module has these inherent benefits as well.

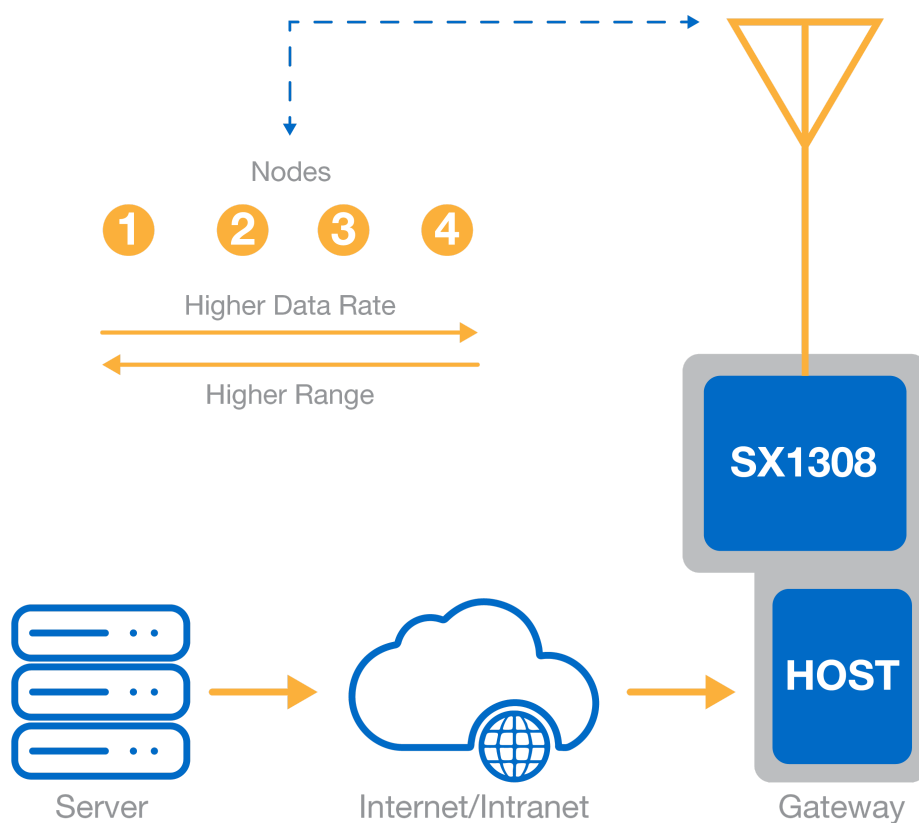



Figure 10: System Architecture

Due to the fact that the combination of spreading factors and signal bandwidths results in different data rates the use of “Dynamic Data-Rate Adaption” becomes possible. That means that LoRa nodes a large distance away from the Gateway can use higher spreading factors and therefore have a lower data rate. LoRa nodes which are closer to the concentrator can use lower spreading factors and therefore can increase their data rate.

Due to the fact that spreading factors are orthogonal and the RAK2246 Concentrator can demodulate on 8 channels at the same time, channel capacity of a LoRaWAN Gateway is increased compared to traditional cellular networks.

Firmware

The LoRa MAC specification is currently driven by the companies Semtech, IBM and Actility. Currently all available software, firmware and documentation can be found and downloaded from the open source project LoRa-net hosted on <https://github.com/Lora-net> 

This project considers all parts that are needed to run a network based on LoRa technology. It includes the node firmware (several hardware platforms are supported), the Gateway host software (HAL driver for SX1308, packet forwarder) and a server implementation.

It is highly recommended to utilize the latest HAL as provided by Semtech.

Configuring the Gateway

You can login to the Gateway using an SSH client like PuTTY. For more details on the configuration and management of the Gateway please visit the link below:

[RAK7246G WisGate Developer D0 Gateway User Manual](#)

Models / Bundles

Order Information

Part Number	Package	Description
RAK7246G	1x LoRa Antenna, 1x GPS Antenna, 1x Micro USB Cable, 1x 16GB TF Card	Supports region: IN865 / EU868 / US915 / AU915 / AS923 / KR920

Last Updated: 11/19/2020, 1:38:13 PM
